

40W LED BATTEN 1200MM GH-T40 HL 52k

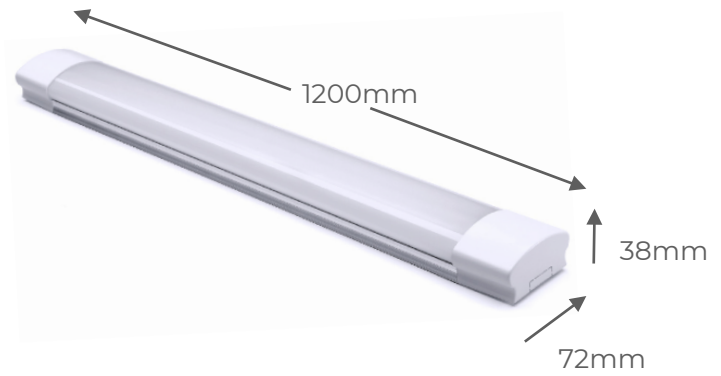

KEY INFORMATION

LUMEN OUTPUT	5200 Lumens
INPUT POWER	40W
REPLACES	2 x T8 or T5 Tubes
HOLE CUTOOUT SIZE	N/A
INSTALL	Ceiling Mountable, can be suspended
DIMMING OPTIONS	Non Dimmable
TRIM COLOUR	White
WARRANTY	4 Years
IP RATING	IP44
FLICKER FREE	Yes

PHOTOMETRIC

EFFICACY	130 Lms/W
LUMEN OUTPUT COLOUR	Bright 5200k
CRI	>90
BEAM ANGLE	120°

ELECTRICAL

DRIVER	Internal
SUPPLY INPUT	AC100-265V, 50-60Hz
POWER FACTOR	0.96
LIFESPAN	50000Hrs

CONSTRUCTION

MATERIAL CONSTRUCTION	Aluminium housing and PC cover
SHADE/HOUSING	White with frosted PC Lens
LOW HEAT OUTPUT	Yes
TOTAL WEIGHT	0.7kg per piece
DIMENSIONS	1200x72x48mm
PACKED DIMENSIONS	1224x78x45mm/pce
CERTIFICATION	SAA, RCM

DESCRIPTION:

NEW High quality 40W 1.2m High Lumen LED batten fitting. With elegant appearance, slim with easy installation which can be connected in series. Very bright - up to 40% brighter than normal fittings - high CRI and no flicker or frequency, which improves working conditions and safety as well as reducing fatigue. The Blue Filtered chips minimize harmful blue light but retain clear white lighting.

Suitable for all application requiring accurate light.

Comes with connector (for hard wire option).

FEATURES:

- More efficient with high lumens
- CRI>95
- Bright white (5200k)
- Uniform light output
- Replaces 2 x T8 or T5 tubes
- Long 4 Year Warranty
- Long lifespan 50 000 hours

SUITABLE FOR:

- Garages, sheds and workshops
- Shopping malls
- Office buildings
- Warehouses and factories
- Bars and restaurants
- Public areas - stairways, lobbies, reception areas, corridors